

# UT620C+

## Micro Ohm Meter

### User Manual



## Preface

Thank you for purchasing this brand new product. In order to use this product safely and correctly, please read this manual thoroughly, especially the Safety Instructions part.

After reading this manual, it is recommended to keep the manual at an easily accessible place, preferably close to the device, for future reference.

## Limited Warranty and Liability

Uni-Trend guarantees that the product is free from any defect in material and workmanship within one year from the purchase date. This warranty does not apply to damages caused by accident, negligence, misuse, modification, contamination or improper handling. The dealer shall not be entitled to give any other warranty on behalf of Uni-Trend. If you need warranty service within the warranty period, please contact your seller directly.

Uni-Trend will not be responsible for any special, incidental or subsequent damage or loss caused by using the device.

## Contents

1.	<b>Safety Information</b> .....	4
2.	<b>Overview</b> .....	5
3.	<b>Range and Accuracy</b> .....	5
4.	<b>Specifications</b> .....	6
5.	<b>Structure</b> .....	8
5.1	<b>External structure</b> .....	8
5.2	<b>Functional buttons</b> .....	8
5.3	<b>LCD display</b> .....	9
6.	<b>Operating Instructions</b> .....	10
6.1	<b>Power on/off</b> .....	10
6.2	<b>Battery power checking</b> .....	10
6.3	<b>Precision test of resistance</b> .....	10
6.4	<b>Data hold/saving</b> .....	13
6.5	<b>Backlight control</b> .....	14
6.6	<b>Data reading/deletion</b> .....	14
6.7	<b>Switching automatic and manual modes</b> .....	15
6.8	<b>Data upload</b> .....	17
6.9	<b>Lead resistance calibration (Eliminating residual resistance)</b> .....	17
7.	<b>Battery Charging</b> .....	18
8.	<b>Packing List</b> .....	19
9.	<b>Troubleshooting</b> .....	19

## 1. Safety Information

To better use the product, please read the User Manual carefully and strictly follows all safety rules and precautions listed in the Manual.

- ◆ Pay special attention to the safety when using the Meter.
- ◆ Do not measure any energized object. Please be sure that the measured resistor or metallic object is not energized before measurement, otherwise it may pose a risk of damaging the Meter.
- ◆ When the low battery symbol appears, please charge the battery for 5~8 hours in time.
- ◆ If the Meter is not used for a long time, please charge the battery once every 1 to 2 months.
- ◆ Please stop using the Meter if the test lead is broken during use.
- ◆ Do not place or store the Meter in environments with high temperature/humidity, dew, direct sunlight.
- ◆ The Meter is a precision instrument, please perform regular servicing on it. Keep the Meter and test leads clean. Do not drop the Meter.
- ◆ The use, disassembly and repair of the Meter must be performed by authorized professionals.
- ◆ If the use of the Meter presents a risk due to the Meter itself, please stop using the Meter and seal it immediately, then send it to authorized body for maintenance.
- ◆ The dangerous symbol "&" at the Meter and User Manual warns that the user must perform safe operations according to the instructions.
- ◆ Before each use verify tester operation by measuring a known resistance that is within the rating of this unit
- ◆ Use approved by IEC/EN 61010-031 standard test leads .

## 2. Overview

DC Low Resistance Meter (also known as “Micro Ohm Meter”, “Ohmmeter”, and “DC Resistance Tester”) is designed with microprocessor technology and 4-wire testing method, which ensures safety and delivers accurate and reliable testing results. The Meter is mainly used to measure the conductor resistance of cable; the contact resistance of switch, connector, and relay; the riveting resistance of metal, and to test the connection resistance between metallic components; the low resistance, the resistance of connection conductors between the ground poles of grounding grid; the contact resistance; etc.

UT620C+ consists of the Meter (designed with large LCD), PC software, test leads, communication cable, etc. Up to 499 groups of data can be saved and the resistance measurement range is 0.001mΩ~300.0kΩ. The PC software has multiple functions including data reading, data saving, report generation, and more.

## 3. Range and Accuracy

Ambient temperature: 23±5°C

Ambient humidity: 45~75%RH

External magnetic field: None (Earth’s magnetic field)

Battery voltage: Available effective battery voltage

Temperature coefficient: A testing error of ±0.01% will be added per degree (Celsius) if test is performed in temperature of >28°C or <18°C.

Model	Range	Accuracy	Resolution	Max. testing current
UT620C+	0.001mΩ~10.000mΩ	18°C~28°C; <75%rh: ±(0.1%FS+20dgt)	0.001mΩ	1A
	10.01mΩ~100.00mΩ		0.01mΩ	1A

	100.1mΩ~1000.0mΩ		0.1mΩ	100mA
	1.001Ω~10.000Ω		0.001Ω	10mA
	10.01Ω~100.00Ω		0.01Ω	1mA
	100.1Ω~1000.0Ω		0.1Ω	100uA
	1.001KΩ~10.000kΩ		0.001kΩ	10uA
	10.01KΩ~100.00kΩ		0.01kΩ	10uA
	100.1KΩ~300.0kΩ		0.1kΩ	3uA

- 1Ω (ohm)=1000 mΩ
- Overrange indication: “OL” is displayed if the measurement range is exceeded.

## 4. Specifications

Functions	Measure the conductor resistance of cable; the contact resistance of switch, connector, and relay; the resistance of coil, motor, and transformer winding; the riveting resistance of metal. Test the connection resistance between metallic components; the low resistance, the resistance of connection conductors between the ground poles of grounding grid; the contact resistance; etc.
Testing method	4-wire method
Testing current	≤1A
Open-circuit voltage	≤4.2V
Power	Measurement power: < 8W
Power supply	DC 3.7V 3200mAh rechargeable lithium battery
Backlight	Adjustable backlight on grey screen (Suitable for use in dark environments)
Display	LCD display with backlit grey screen
LCD size	102mm × 50mm (Length × Width)

Meter dimensions	161mm × 117mm × 63mm (Length × Width × Height)
Length of test lead	About 70cm (Red ×1; Black × 1)
Measurement speed	About 2 times/s
USB port	With Type-C port
Communication cable	Type-C cable (1 pc)
Data storage	499 groups of data (“SAVE” appears to indicate data storage. “FULL” is displayed to indicate full storage.)
Data reading	Data reading function: “READ” is displayed
Overrange indication	Overrange function: “OL” is displayed
Displaying battery power	Displaying battery power in real time (If the remaining battery power is less than 25% of fully-charged battery power, please charge the battery in time)
Auto power off	Powering off automatically 15 minutes of inactivity, with the symbol “APO” as an indication.
Power consumption	Standby: About 110mA (Backlight off) Backlight is ON when the Meter is turned on: About 130mA (Backlight on) Measurement: About 1.1A Max
Weight	Meter: about 590g (including battery) Test lead: about 145g
Operating temperature and humidity	-10~50°C; <75%rh
Storage temperature and humidity	-20~60°C; <75%rh
Certification	CE Certified
Applicable standards	IEC61010-1, Pollution Degree 2, indoor use, JYG724-1991 “Verification Regulation of DC Digital Ohmmeter”, JJG116-1993 “Verification Regulation of DC Resistors”, “DL/T967-2005 Verification Regulation of Loop Resistance Tester and DC Resistance High-Speed Tester”

## 5. Structure

### 5.1 External structure

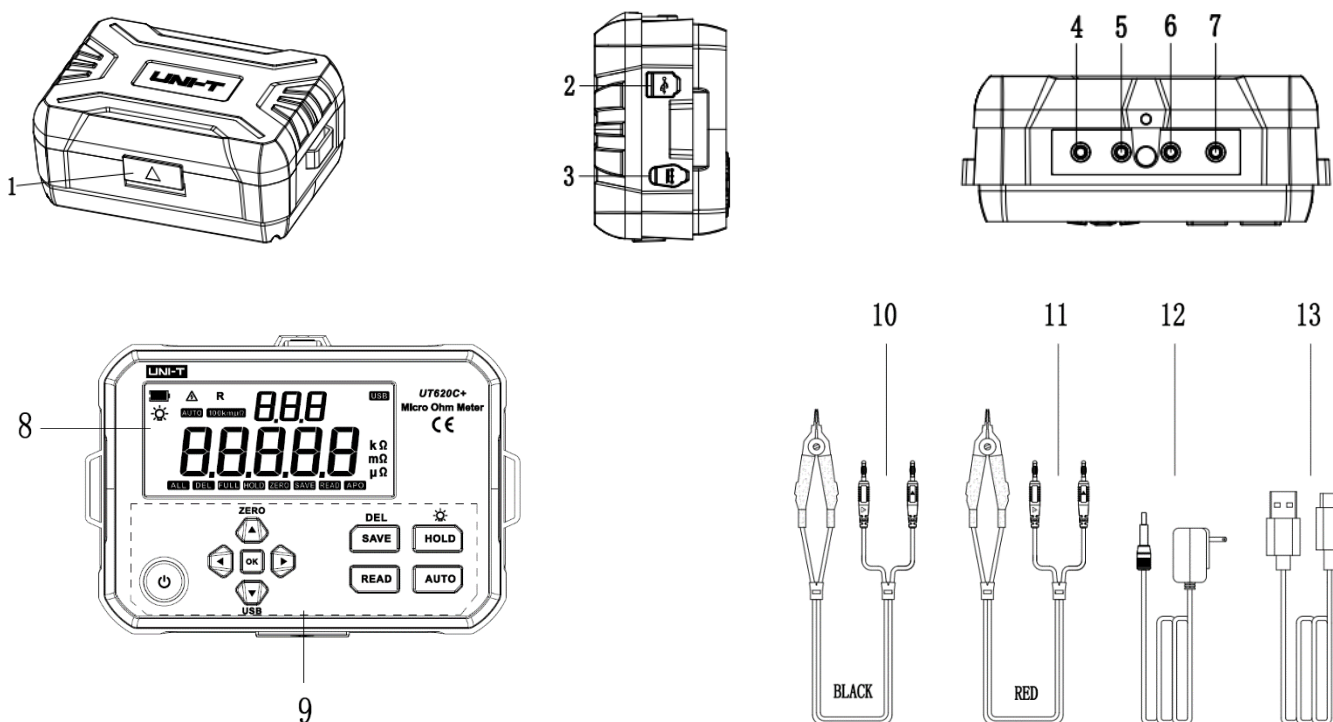

1. Slider for opening the cover
2. USB communication port
3. Charging port
4. C2 terminal
5. P2 terminal
6. P1 terminal
7. C1 terminal

8. Display screen
9. Functional buttons
10. Black test clip
11. Red test clip
12. 5V/2A charger
13. USB Type-C cable

### 5.2 Functional buttons

1. POWER button
2. Up arrow button/Zeroing button
3. Left arrow button
4. Down arrow button/USB communication button
5. OK button
6. Right arrow button
7. Data saving/deletion

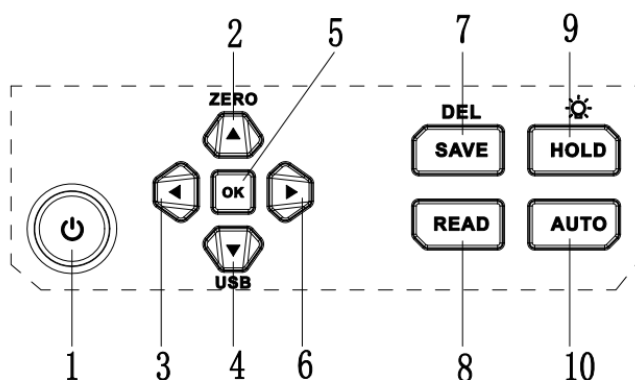

8. Data reading
9. Data hold/Backlight
10. Auto/Manual mode switching

### 5.3 LCD display

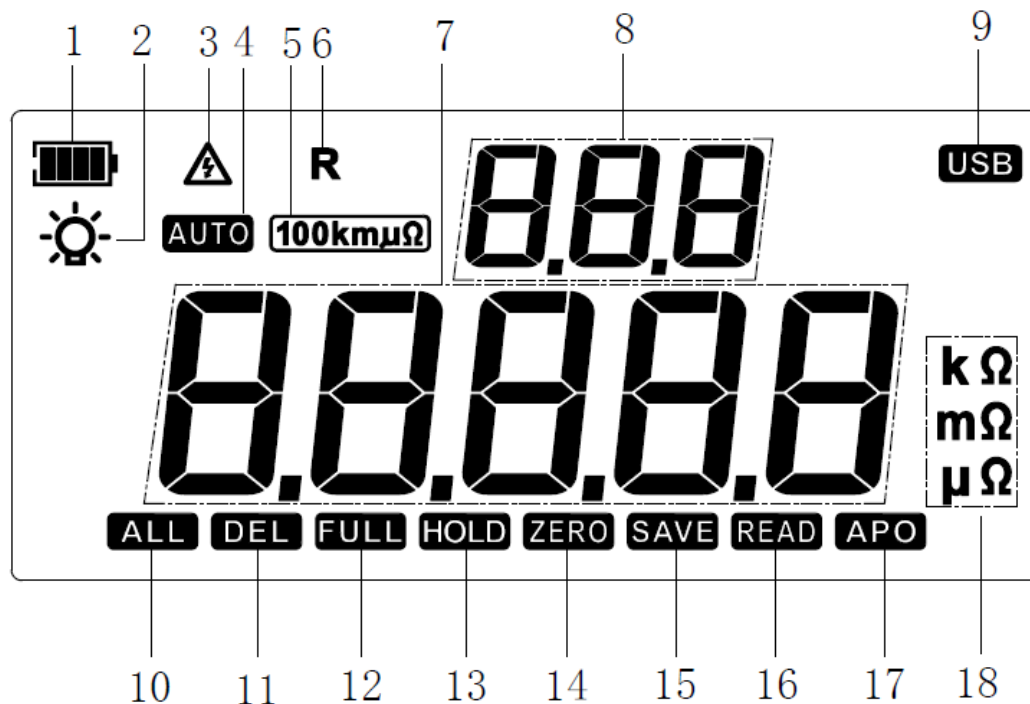

1. Battery power indicator (Indicating real-time battery power)
2. Backlight lights up (This symbol appears when turning on the backlight)
3. Dangerous operation symbol (This symbol is displayed when measuring with an external AC current)
4. Automatic measurement symbol (This symbol appears in the auto mode and disappears in manual mode)
5. Measurement position symbol (Current position is displayed. There are 10 positions: 100uΩ~100kΩ)
6. Resistance measurement symbol (The symbol indicates the Meter is in resistance measurement state)
7. Displaying measured resistance
8. Displaying the total number of saved data
9. USB symbol (Displayed when starting USB communication)
10. ALL symbol (Flashing when all saved data are selected)
11. DEL symbol (This symbol indicates the data is to be deleted. Press the "OK" button to perform deletion operation.)
12. FULL symbol (Indicating full data storage)
13. HOLD symbol (Current displayed measured value is locked)

14. ZERO symbol (Flashing once when zeroing operation is completed)
15. SAVE symbol (Flashing once each time a set of measurement data is saved.)
16. READ symbol (Displayed in data reading mode)
17. APO symbol (Powering off automatically after 15 minutes of inactivity)
18. Displaying the unit of measured value

## 6. Operating Instructions

### 6.1 Power on/off

Long press the “” button for 2 seconds to power on/off the Meter. The symbol “APO” is displayed at the bottom right corner of the display screen after the Meter is powered on. The Meter will be powered off automatically in 15 minutes of inactivity.

### 6.2 Battery power checking

The battery power is displayed at the top left of the LCD after the Meter is powered on for 2 to 4 seconds. 4 levels of battery power are displayed if the battery is fully charged. If the battery power is decreased, then the number of displayed levels of battery power will be decreased accordingly. When the symbol “” is displayed, it indicates low battery, please charge the battery in time. Sufficient battery power can ensure measurement accuracy. If the battery power is insufficient, the accuracy and stability of low resistance measurement will be affected.

### 6.3 Precision test of resistance

#### Precautions

1. Please remove the insulation and oxidation layers on the surface of measured object before test.
2. It is forbidden to perform energized test for measuring resistance or DC resistance. Energized test may pose a risk of damaging the Meter.
3. Please ensure a reliable connection between test clip and measured resistor or conductor during test.

4. The components and parts heat up significantly during operation for low resistance measurement (measured resistance: <math><100\text{m}\Omega</math>). It is recommended that the test time shall not exceed 2 minutes and the test interval shall be 10 seconds.

Power on the Meter, connect the test leads with the measured resistor, then measure the resistance of the resistor. As shown in Figure 6-1.

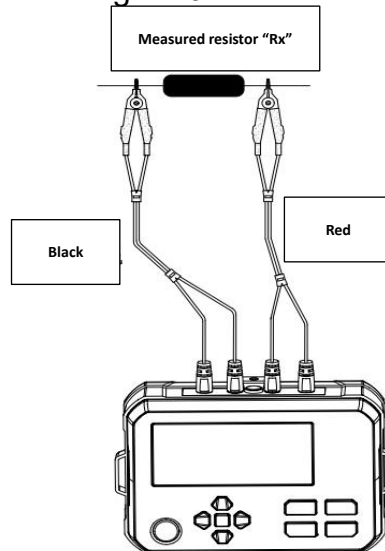

Figure 6-1

Test the resistance between electric meter box, ground wire, and down conductor. As shown in Figure 6-2.

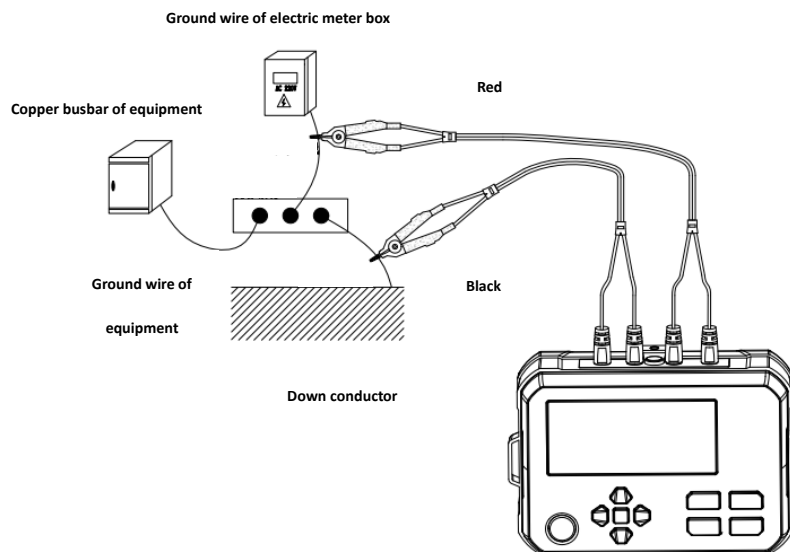

Figure 6-2

Test the resistance between two metallic connectors. As shown in Figure 6-3.

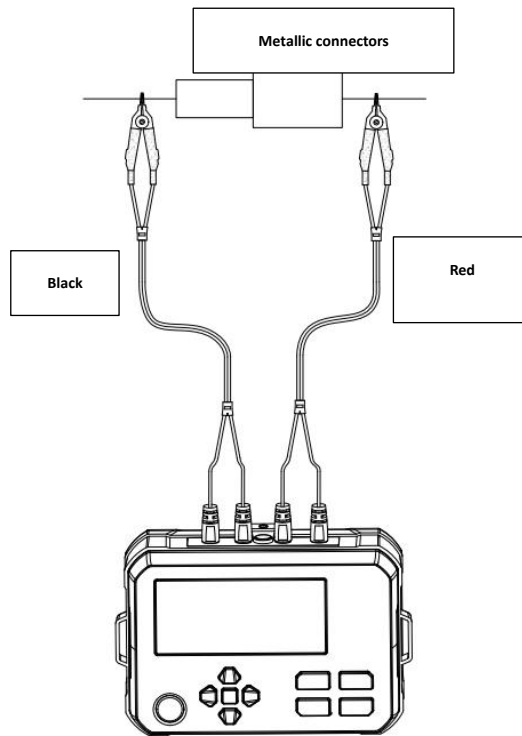

Figure 6-3

Test the contact resistance of relay. As shown in Figure 6-4.

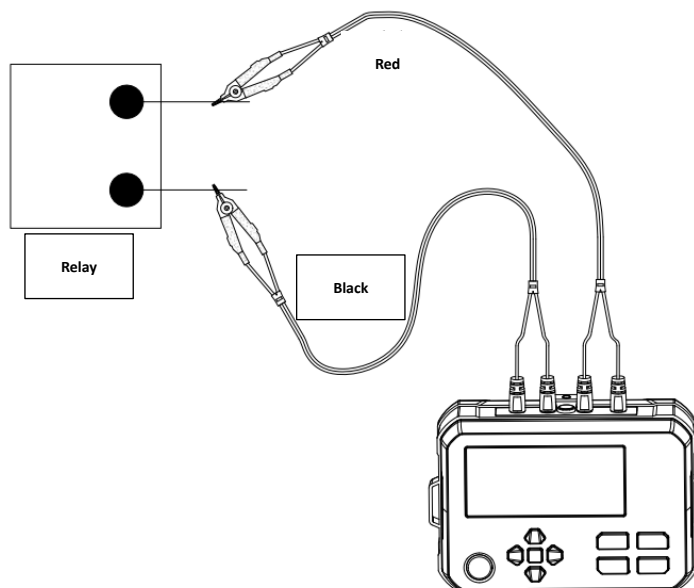
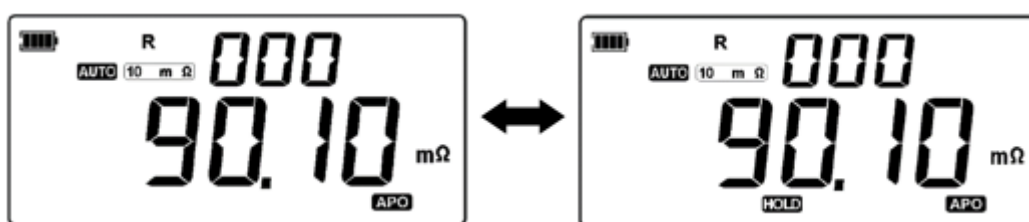

Figure 6-4

## 6.4 Data hold/saving

In resistance measurement state, press the “HOLD” button to hold the currently measured resistance, release the fixture and the object to be measured, then the measured value will still be displayed. Press the “HOLD” button again to cancel holding the measured value.



In resistance measurement state, press the “SAVE” button to perform numbering automatically save the currently displayed data, then the symbol “SAVE” will appear in a short time and the displayed total number of data will be increased by 1. If the total number of saved data is up to 499, please delete the saved data before saving new data.

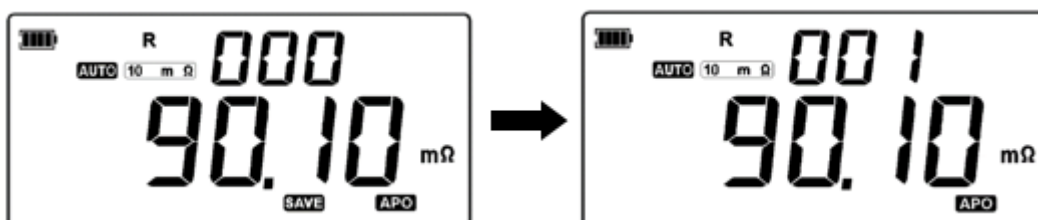

Note: The data hold and saving functions can be used for low resistance measurement. The accuracy of low resistance measurement will be affected by the heat generated by the components and part, so please connect the fixture to the object to be measured, hold and read the measurement result after measurement is completed and the measurement result is displayed, then disconnect the measured object from the fixture after the data is held. To

save the currently held data, please press the “SAVE” button. After reading and saving the data, press the “HOLD” button to exit the data hold and saving functions for next measurement.

## 6.5 Backlight control

Long press the “HOLD” button for 2 seconds to turn on/off the backlight when performing measurement in dark environments.

## 6.6 Data reading/deletion

**Data reading:** After the Meter is powered on or the measurement is completed, press the “READ” button to switch to data reading mode, then the symbol “READ” and the recently saved data are displayed. Press “▲” or “▼” button to read a single set of data; press “◀” or “▶” button to read 10 more or less sets of data.

In data reading mode:

If the number of saved data is 0, the symbol “NULL” will be displayed.

If the data storage is full, the symbol “FULL” will be displayed. Please delete the saved data to ensure that new test data can be saved normally.

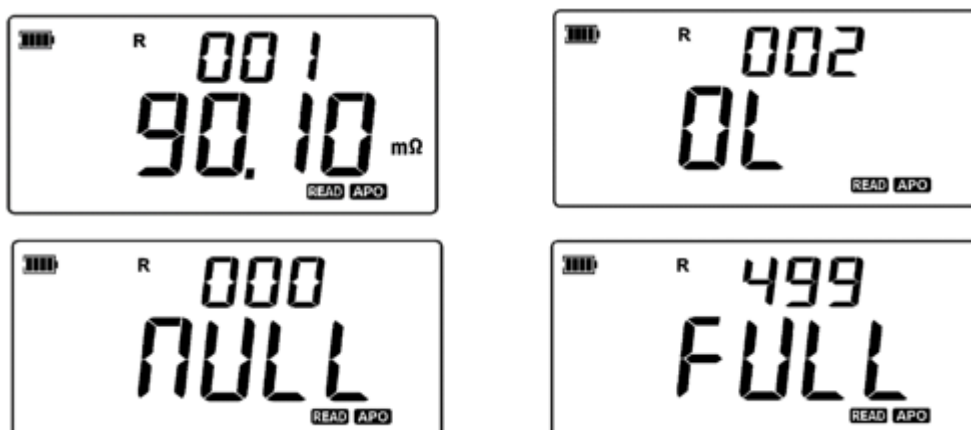

**Delete a single set of data:** In data reading mode, short press the “SAVE” button to enter

or exit the state of deleting a single set of data (with the symbol “DEL” blinking). If the “OK” button is pressed then, the currently displayed data will be deleted, and next set of data will be displayed automatically. After that, the user can still press the “OK” button to delete data or long press the “SAVE” button again to exit the state of deleting a single set of data.

**Delete all data:** In data reading mode, long press the “SAVE” button to enter or exit the state of deleting all data (with the symbols “ALL” and “DEL” blinking simultaneously). If the “OK” button is pressed then, all data will be deleted (with the symbol “NULL” displayed at the same time) and the Meter will exit the data deletion state.



**Exit the data reading mode:** When the Meter is not in the data deletion state (single set of data or all data) in data reading mode, press the “OK” or “READ” button to exit the data reading mode and return to the resistance measurement mode.

## 6.7 Switching automatic and manual modes

Press the “AUTO” button to switch between automatic and manual modes. When switching to manual mode, the symbol “AUTO” disappears and the current measurement position is displayed. The default measurement position is 100kΩ after automatic mode is switched to manual mode.

The measurement position can be switched by pressing “▲” or “▼” button. Press “▼” button to switch to a measurement position with smaller resistance (the measurement position with lowest resistance is 100uΩ), or press “▲” to switch to a measurement position with larger resistance (the measurement position with highest resistance is 100kΩ).

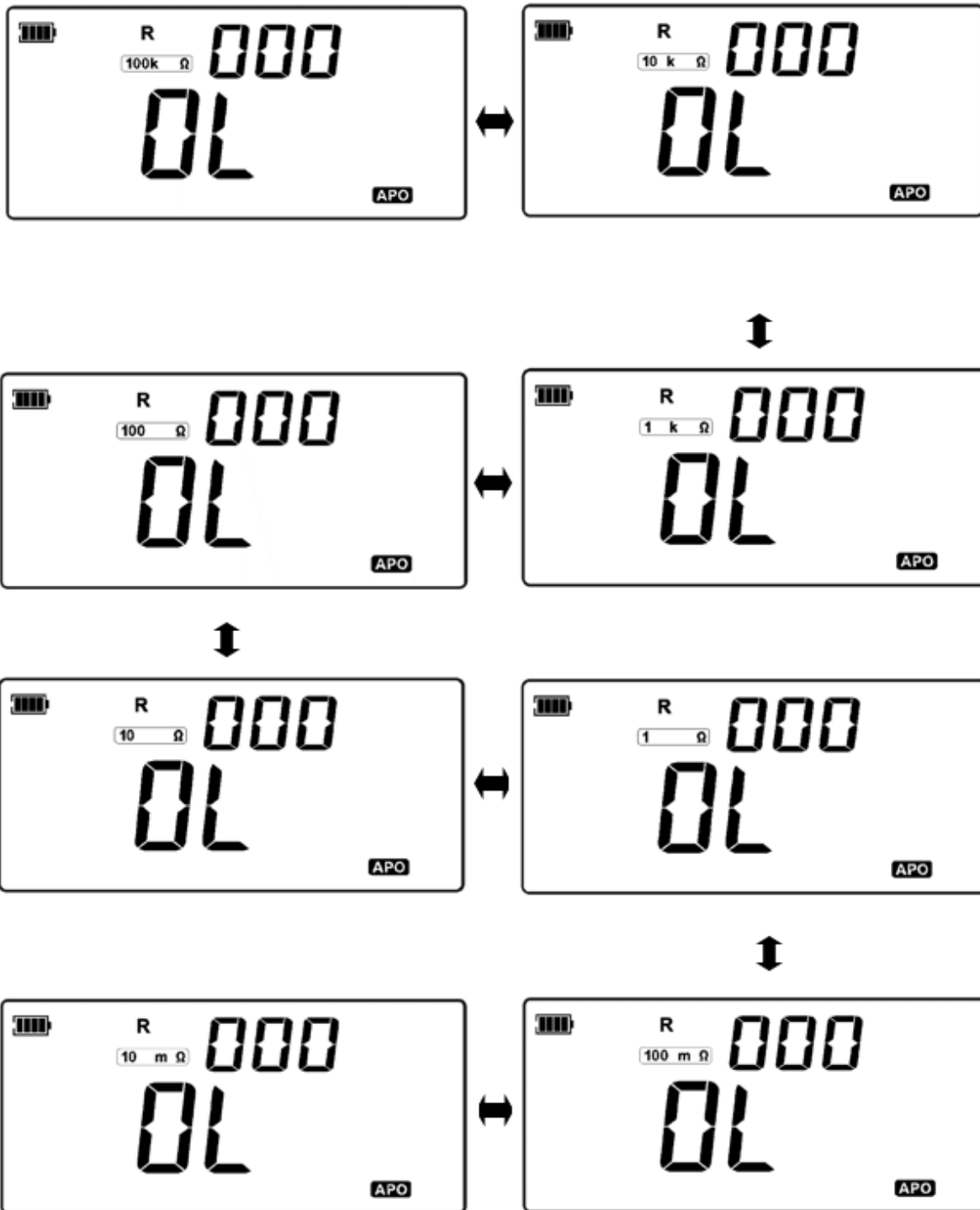

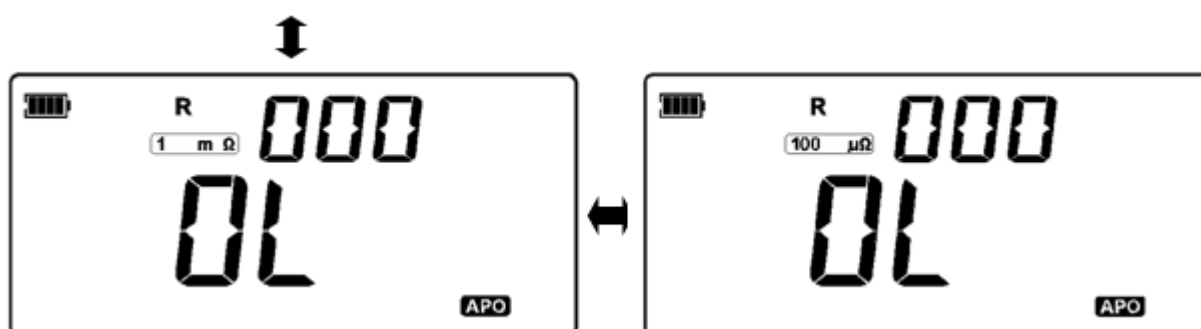

## 6.8 Data upload

Connect the Meter to a computer via USB Type-C cable, power on the Meter, then run the PC software on the computer. After successful connection, long press the “▼” button to enter USB communication mode, then the symbol “USB” appears on the display screen. The PC software can read and save the storage data.

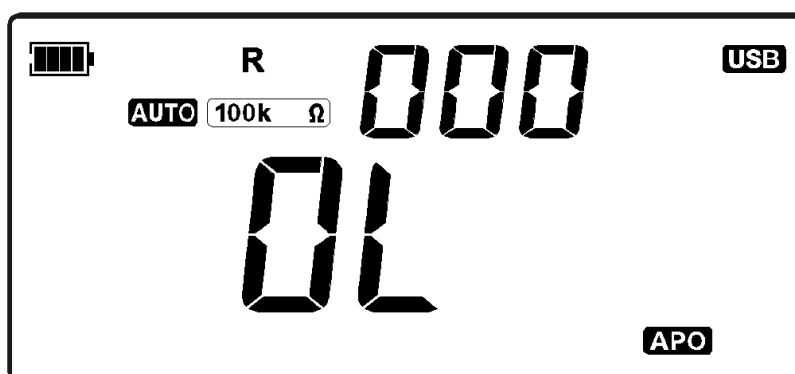

The PC software has multiple functions including data reading, data saving, and more.

## 6.9 Lead resistance calibration (Eliminating residual resistance)

As shown in the Figure below, connect the binding posts (the ends with white arrows) of both test clips to the Meter according to the correct order, power on the Meter, short-circuit the two test clips (Note: The clamping sections with white arrows of the two clips shall be clamped on the same side), long press the “▲” button for 2 to 3 seconds after the displayed reading stabilizes, then the symbol “ZERO” appears on the display in a short time to indicate that lead resistance calibration is completed.

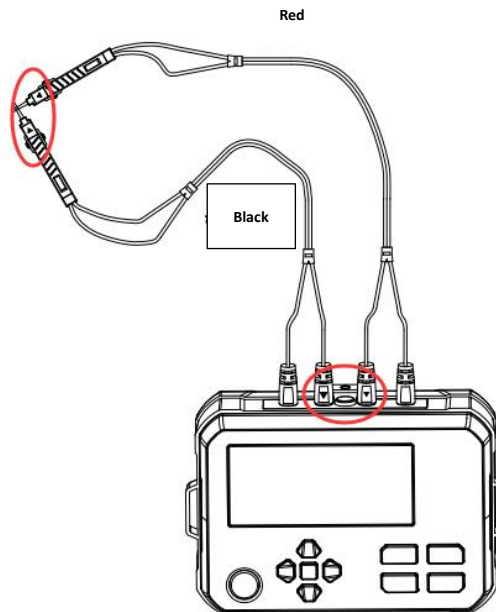

## 7. Battery Charging

1. If the remaining battery power is less than 25% of fully-charged battery power, please stop resistance measurement and charge the battery in time. The measurement accuracy can be affected by low battery, so please make sure that the battery power is sufficient to guarantee the measurement accuracy.
2. The fully charged time for the battery is 5 to 8 hours.
3. Please charge the Meter through the supplied 5V/2A charger to ensure the Meter is charged normally.
4. Dynamic charging indicator is displayed during charging. When 4 levels of battery power appear and the charging indicator is no longer dynamic, it means that the battery is fully charged.
5. If the Meter is not used for a long time, please charge the Meter regularly to ensure the battery life.

## 8. Packing List

Meter	1 pc
Carrying case	1 pc
USB-C cable	1 pc
UT620C+ test leads	2 pcs (Red × 1; Black × 1)
Charger	1 pc
User manual	1 <a href="#">pc</a>
Straps	1 <a href="#">pc</a>
Download the product manual or software guide	1 <a href="#">pc</a>

## 9. Troubleshooting

If “OL” appears on the LCD and no resistance is displayed for resistance measurement, then the reasons may include exceeding the resistance measurement range, poor contact between test clip and measured resistor, poor contact between test clip and binding post, etc.

***The contents of the manual are subject to change without further notice!***